

ELECTRIC
CONVECTION
OVENS

OV-250

[XA006 "Mini Roberta"]

OV-350

[XA015 "Mini Arianna
w / finishing control"]

OV-400

[XA030 "Arianna"]

OV-500

[XA085 "Elena"]

OV-600

[XA090 "Rossella"]



INSTRUCTION MANUAL

This booklet contains important information about your Cadco-Unox Convection Oven. Keep it in a safe place.

ENGLISH

For Information
on the **Cadco Oven by UNOX**
Contact:

CADCO, LTD.

145 Colebrook River Road,
Winsted, CT 06098

Phone: 860-738-2500

Fax: 860-738-9772

E-mail: info@cadco-ltd.com

07 / 2003

WELCOME TO CADCO!

We want you to have immediate success with your new Cadco-Unox Convection Oven.

These state of the art convection ovens are manufactured for Cadco by Unox SPA of Padua, Italy, to the highest standards. By following the guidelines and reading the tips contained in this instruction manual you will be convection cooking like an ol' pro in no time. Cadco will help you find the perfect oven for your needs, and provide customer support after the purchase.

The Cadco website, at www.cadco-ltd.com, provides a wealth of information relating to service and food issues.

All our Cadco staff e-mail addresses will be listed on the website.

The Cadco toll free number gives you access to our on staff Certified Executive Chef. Most calls are answered within 24 hours. To reach any of the Cadco professionals call 877.603.7393.

INDEX:

I. Instructions for the Installer Page 3

- 1. Data Plate Page 3
- 2. Certifications Page 3
- 3. Installation -Preliminary operations Page 3
 - 3.1 Feet Assembly Page 3
 - 3.2 Installation Location Page 4
 - 3.3 Remove Protective Film Page 4
- 4. Installation Page 4
 - 4.1 Electrical Connection Page 4
 - 4.2 Water Connection (OV-500 & OV-600 only) Page 5
 - 4.3 Maintenance Page 5

II. Instructions for the User Page 6

- 1. "Burn In" Oven Before First Use Page 6
- 2. Features and controls Page 6
 - 2.1 Preheat Indicator Light Page 6
 - 2.2 Temperature Control Page 6
 - 2.3 Timer Dial Page 6
- 3. Special Cadco-Unox Oven Features Page 6
 - 3.1 "End Of Cycle" Alarm Tone Page 6
 - 3.2 Interior Light Page 6
 - 3.3 Finishing Feature (only OV-350) Page 6
- 4. Cleaning & Maintenance Page 7
- 5. Door Removal Instructions Page 8
- 6. Troubleshooting Page 8

III. Convection Cooking Page 9

- 1. Cooking Principles Page 9
- 2. Cooking Page 9
- 3. Times and Temperatures Page 10

IV. Technical Data: Electrical Schematics, Drawings Page 12

- 1. XA006 - OV250 Page 12
- 2. XA015 - OV350 Page 13
- 3. XA030 - OV400 Page 14
- 4. XA085 - OV500 Page 15
- 5. XA090 - OV600 Page 16

I. INSTRUCTIONS FOR THE INSTALLER

Dear customer, we thank you and compliment you for having purchased one of our products.

The warnings and suggestions that follow concern the phases for proper installation, use and maintenance for your safety and for the best use of the appliance.

1. DATA PLATE

The data plate is positioned on the right side panel.

The technical characteristics are identified in the enclosed page "technical data".

2. CERTIFICATIONS



CSA C-US BRAND SERIE XA

Certificate of Compliance
N.202281-1008284

Applicable Requirements:

CAN/CSA-C22.2 No. 100-1995 - Motors and Generators.

CSA Std C22.2 No. 109-M1981 – Commercial Cooking Appliances.

UL Std No. 197 - Commercial Electric Cooking Appliances.

UL Std No. 1004 - Electric Motors

"The "C" and "US" indicator adjacent to the CSA Mark signifies that the product has been evaluated to the applicable ANSI/UL and CSA Standards, for use in the U.S. and Canada. This includes products eligible to bear the NRTL indicator. NRTL, i.e. Nationally Recognized Testing Laboratory, is a designation granted by the U.S. Occupational Safety and Health Administration (OSHA) to laboratories which have been recognized to perform certification to U.S. Standards.



NSF BRAND SERIE XA

Certificate N. 79610/79610B
N. 79610/79611/B

NSF International recognizes UNOX SPA

products as complying with ANSI/NSF 04. Standard 004 - Commercial Cooking, Rethermalization and Powered Hot Food.

3. INSTALLATION – Preliminary Operations

All the electrical connections and installations must be done by qualified personnel in compliance with all local codes.

3.1 FEET ASSEMBLY (If applicable)

The Cadco-Unox models OV-250 and OV-350 are shipped with feet installed. Some other model ovens are shipped without the feet being installed, and must be assembled. If your convection oven has feet, do not install or use the oven without them. The feet are shipped in the cooking cavity and must be assembled.

Screw the support feet into the bottom of the oven as shown in the illustration. After assembling the feet, the oven's height may be adjusted by screwing or unscrewing the feet to level the unit.

The models OV-500 and OV-600 require washers when the feet are assembled.

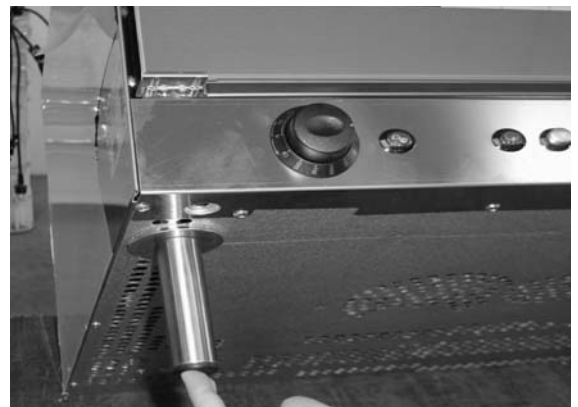

NOTE - DO NOT USE YOUR OVEN WITHOUT INSTALLING THE FEET.

3.2 INSTALLATION LOCATION

Make sure you have the correct power supply for the oven model you have purchased. Check the technical data sheets at the back of this manual if you are in doubt.

Do not install any Cadco-Unox Convection Oven directly on the floor. Cadco has oven stands to perfectly elevate your oven as well as provide pan storage.

OST-34A for models OV-350 and OV-400
OST-56A for models OV-500 and OV-600

If the oven must be placed near walls, dividers, or moldings Cadco recommends they be made of non-combustible materials. Be sure to observe all safety and fire codes when positioning your convection oven.

All of our convection ovens have a vapor vent in the back of the unit. When installing your convection oven, leave a space of 4" [minimum] between the back of the oven and the wall, and 2" minimum on the top and sides. Where applicable, ventilation hood requirements vary according to local codes.

We do not suggest using the Cadco-Unox Convection Ovens for built in applications.

Measure to make sure that your new oven will fit in your available space.

3.3 REMOVE THE PROTECTIVE FILM

Be sure to remove the laser film from the



exterior walls before you begin cooking food in your new Cadco convection oven. Most solvents or degreasers will remove any residue.

4. INSTALLATION

4.1 ELECTRICAL CONNECTION

The connection to the electrical power supply network must be done according to the standards in force.

Before connecting make sure that the voltage and the frequency correspond to that stated on the data plate on the oven.

Place a bi-polar switch between the oven and the network accessible after installation, whose contacts have a minimum opening distance of 0.1 inches, with an appropriate input (for example, magnetothermal switch). When the oven is in operation, the power supply voltage must not vary from the value of the nominal voltage by more than $\pm 10\%$. The oven must be connected to the ground line of the network.

208-240V 60Hz

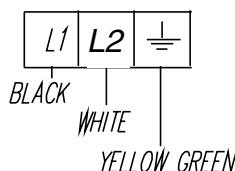

XA030/OV-400
XA085/OV-500

120V 60Hz

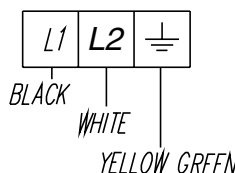

XA006/OV-250
XA015/OV-350

208 - 240V ~

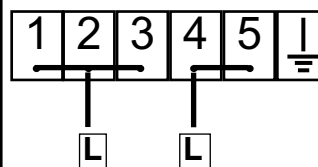

XA090/OV-600
Use only AWG10 cords

WARNING:

Connect the electrical cable to the terminal-board as indicated in the drawing: insert screw-wise the copper bridge and the electrical cable together under the screw (see diagram below.)

Tighten the screw taking care that the cable and the copper bridge are well gripped under the screw.

A wrong connection can cause an overheating of the terminal board and burn it.

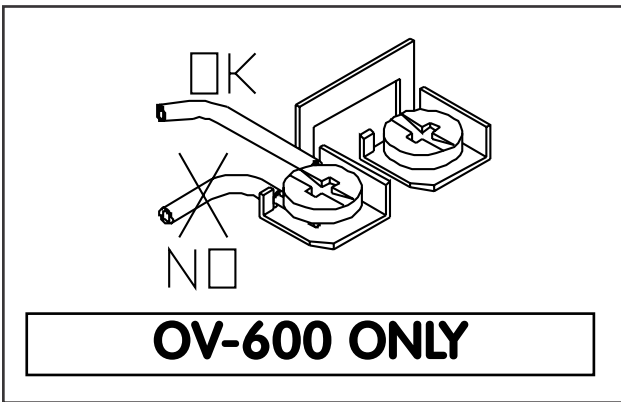

Electrical connection must be a proper outlet for the 3 pronged cord. Before connecting power, make sure the voltage and frequency correspond to the data plate on the oven (120 volts/60hz.), and that your electrical circuit can handle the 12.5 amps used by the oven in addition to any other appliances operating on the same circuit.

4.2 WATER CONNECTION - Applies only to OV-500 and OV-600

WATER CONNECTION TO THE NETWORK:

Connect the decalcified water inlet ducts placed on the back of the oven to the specific distribution network by means of a mechanical filter and a cut-off cock. Before connecting the filters, let a certain quantity of water flow to clean the duct from any ferrous slag. The water must have a hardness between 0.5°-5°f (this in order to reduce the formation of limestone deposits inside the electro-valve and inside the cooking chamber) and a pressure value between 0.5-2 bar

(7.25 – 30 psi.) Due to variations in water composition in different areas, you may want to consider using a commercial water filter.

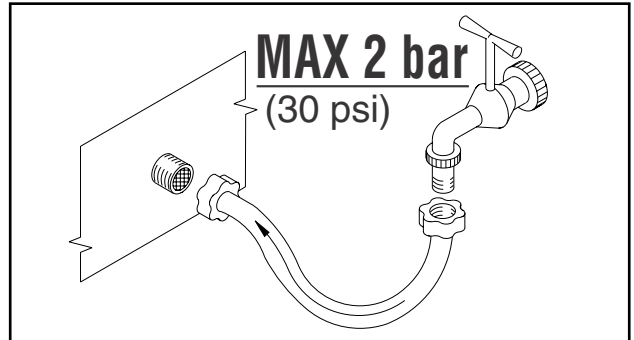

4.3 MAINTENANCE

Before carrying out any type of maintenance it is necessary to disconnect the electrical power supply and wait for the oven to cool down.

II. INSTRUCTIONS FOR THE USER

1. "BURN IN" OVEN BEFORE FIRST USE

Before you start cooking with your new Cadco-Unox Convection Oven you will want to "burn in" the oven. This simple procedure will get the new oven smell out of your oven and off your food.

- Clean the oven with a mild detergent inside and out.
- Turn the temperature control dial to 400F.
- Set the timer for 30 minutes and you'll be ready to start cooking at the end of the cycle.

2. FEATURES AND CONTROLS

2.1 PREHEAT INDICATOR LIGHT

The preheat indicator light will be illuminated when there is heat being added to the cooking chamber. The preheat indicator light will be illuminated periodically throughout the cooking cycle as the oven controls call for more heat.



2.2 TEMPERATURE CONTROL

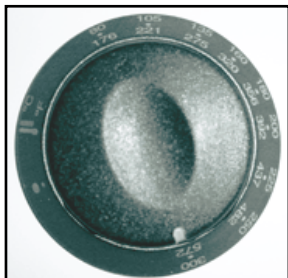

Cadco-Unox temperature controls are extremely accurate. The dial will be turned **clockwise** and used to set your oven cooking temperature in a range 175F to 500F degrees.

2.3 TIMER DIAL



Turning the timer dial **clockwise** allows you to set the cooking time for up to 120 minutes. When the dial is turned **counterclockwise** you are in manual mode with infinite cooking time.

3. SPECIAL CADCO-UNOX OVEN FEATURES

3.1 "END OF CYCLE" ALARM TONE

All Cadco-Unox ovens indicate the end of the cooking cycle with an alarm tone with the exception of the models OV-250 and OV-350

3.2 INTERIOR LIGHT

Models **OV-250** and **OV-350** do not have a light in the cooking cavity.

3.3 FINISHING FEATURE - ONLY on Model OV-350

Model **OV-350** has a special top heating element to enable either browning or broiling functions. The broiler/browning function is activated by turning the temperature control knob clockwise to its most extreme right position. To activate the broiler/browning feature, simply turn the control dial beyond 500F to the furthest point. You will feel a slight resistance as you turn the dial. Beyond this resistance point the browning feature is activated. The browning/broiling feature should be used for no more than 45-60 minute cycles. **It is not designed for constant operation.** Note: The oven fan operates in browning/broiling mode.

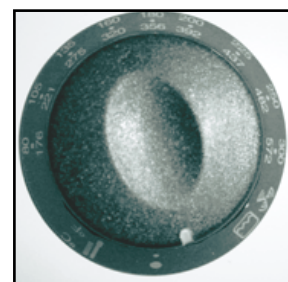

3.4 HUMIDITY FEATURE - ONLY on Models OV-500 and OV-600

Models **OV-500** and **OV-600** have a manual humidity injection feature. The humidity indicator light will illuminate when the humidity feature is being used. Pressing the silver humidity button introduces a spritz of water to the cooking cavity creating a moist cooking environment.



Warning!

To keep from damaging the motors, the humidity injection button should only be pressed for short [5-10 seconds] intermittent periods.

4. **CLEANING AND MAINTENANCE**

WARNING:

Work safely, disconnect the oven and allow it to cool before cleaning or maintenance.

4.1 CLEANING

The oven is not to be cleaned with pressurized water. You could damage the electrical components and an unsafe condition could occur.

Clean the cooking chamber with soap and water. Never use harsh, caustic products or acids.

The rack system is cleaned by removing the retaining screws by the front of the cooking chamber. The racks can then be easily removed and washed.

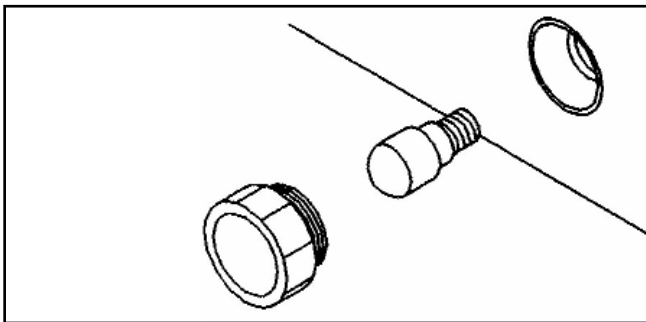

4.2 REPLACEMENT OF THE INTERNAL LAMP (Not

Available On All Models)

To replace the internal lamp do as follows:

- Disconnect the oven from the power supply and let it cool.
- Take out the side rack supports.
- Unscrew the glass cover counterclockwise and replace the lamp with one with the same characteristics (240V-15W-300°C / 572°F).
- To reassemble, follow the reverse order.

5. OVEN DOOR REMOVAL

Convection Oven Door Removal Instructions
(To attach the door, reverse the directions, starting with Step 3)

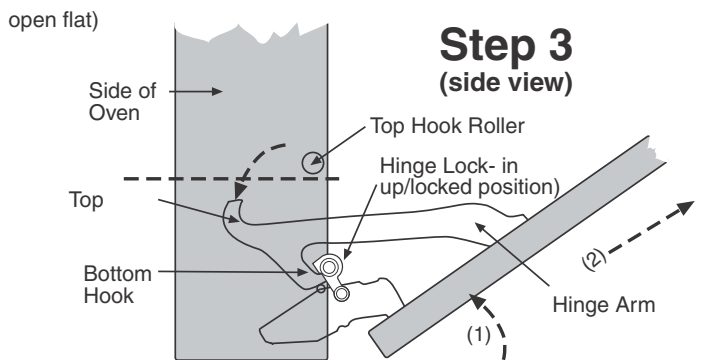
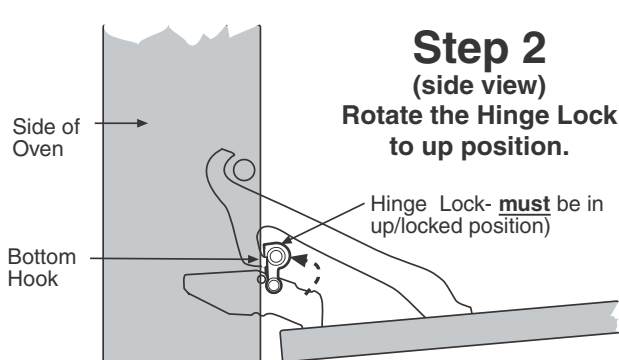
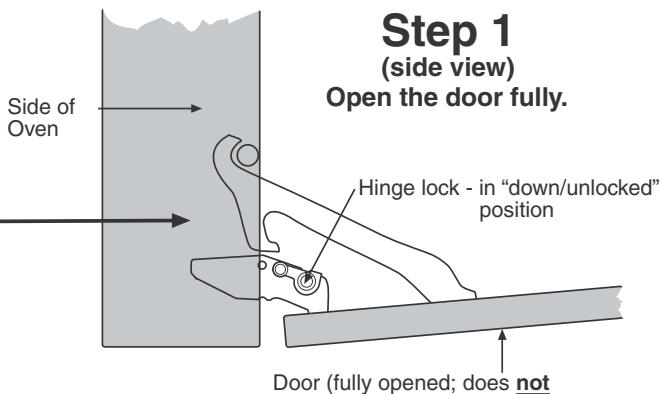
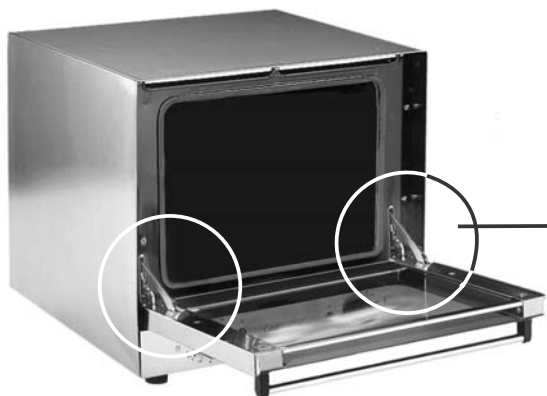

1) Tilt door up at about 45° angle until the Top Hook on the Hinge Arm is lower than the Top Hook Roller, 2) then pull out of the Hinge Slots.

PLEASE NOTE: Hinge Locks may become jostled into the unlocked position by rough handling of the carton during shipping, causing the door to be unhinged from the oven when the carton is opened. If this occurs, follow the directions for attaching the door.

6. TROUBLESHOOTING

<p>1</p> <p>REMOVE/REPLACE BLACK CAP</p>	<p>2</p> <p>PUSH THE RESET BUTTON</p>
--	---

Work safely, disconnect the power and allow the oven to cool before performing any serv-

ice on your oven.

Your Cadco-Unox Convection Oven has an automatic high temperature breaker that protects the oven from overheating or power fluctuations.

If your oven shuts down when you are operating at high temperatures, the following steps will allow you to reset the breaker and resume safe operation.

- Unscrew the black reset knob safety cover at the rear of the oven next to the power cord.
- Press the reset button to the "in" position.

- Securely replace the black safety cover.
- Begin food preparation after the oven is preheated.

If the thermal breaker shuts your oven off, **before turning your oven on, be sure to check your entire circuit** to verify that the total amps being drawn by all the appliances, lights, etc. on that circuit do not exceed the amps available on that circuit.

All repairs should be performed by a Cadco authorized service technician using only genuine Cadco-Unox parts.

III. CONVECTION COOKING

Your Cadco-Unox oven is designed to prepare food, and it should be used for that purpose only.

1. COOKING PRINCIPLES

Accurate times and temperatures assure perfectly cooked foods. Cooking is an art, not a science. People will never agree on the meaning of "done", or "perfectly cooked". Here are some tips that will help ensure success with your convection cooking.

- The temperature of the food going into the oven will affect the cooking time. Frozen foods take longer to cook than refrigerated foods.
- Three trays of chicken will take longer to cook than three pieces of chicken.
- To convert your conventional oven recipes to convection oven production simply reduce the cooking temperature by 25F-30F degrees.
- Most recipes can be converted by having shorter cooking times and/or reducing your cooking temperatures.
- We suggest that you use an instant read probe to help you determine the actual internal temperature of your foods. This will help you safely determine correct times and

temperatures.

- The oven operates between 175°F and 500°F.

Proper air circulation is necessary for successful convection cooking in all convection ovens. We suggest you allow a proper clearance of 1-3 inches between pans when cooking for best results.

Never salt foods while they are in the oven. Salt can damage the interior surfaces of your oven and affect the efficiency of the electrical components.

2. COOKING

Convection ovens work by moving the air inside the cooking chamber to create even heat throughout the oven. This circulating air simply removes the [cool] insulating barrier of air between the cold food and the hot air in the cooking chamber allowing the food to cook more quickly. In essence, the moving air makes heat hotter, as wind chill makes cool colder.

You will want to rely on an instant read, pocket probe while you are getting used to convection cooking. Your probe will help you standardize times and temperatures as well as assuring safe internal food temperatures have been reached.

Preheat your oven to 30F-50F degrees higher than you the temperature you want to cook at. After you have loaded the product into the oven and the door is closed turn the temperature back to your intended cooking temperature.

Check cakes and cupcakes with a toothpick to determine if they are done. If the toothpick comes out "clean" [no batter on it] when pushed into the center of the product, it's done!

We recommend roasting meats on a cooking rack, in a shallow sided pan to allow air to circulate all around the roast.

Salt pulls moisture out of meats. Season your entire roast but only salt the fat portion.

3. TIMES AND TEMPERATURES

Products vary greatly. These times and temperatures may need minor modifications to meet your particular standards. Use your pocket probe to determine what's right for you.

- Rare roast beef – 130F
- Medium roast beef – 140F
- Medium well roast beef – 150F
- Well done roast beef – 160F
- Hamburger – 165F
- Pork – 160F - 170F
- Chicken – 185F done and no "red bone".
- Fish/Seafood – 160F

Here is a handy "Rule of Thumb" for roasting meats at 325F

- Rare roast beef – 15/20 minutes per pound.
- Medium roast beef – 20/25 minutes per pound.
- Well done roast beef – 30/35 minutes per pound.
- Pork – 20/25 minutes per pound.
- Poultry – 20/25 minutes per pound.
- Ham [cured, not fresh] – 12/18 minutes per pound. [Cured hams are already cooked so all we have to do is heat them to 140F]

Here are some common products and their approximate cooking times.

- Cookies 310F-325F for about 10-20 minutes, depending on recipe and cookie size.
- Pies [10"] 350F for 45/60 minutes.
- Cakes [2-8" pans] – 325F for 25/30 minutes.

Check with a tooth pick.

- Pork roast [4lb.] - 325F for 1 hour 20 minutes.
- Hamburgers [1/4 lb. frozen] or 5 oz. skinless

boneless fresh chicken breasts – 400F for 15 minutes.

- Fish sticks [frozen, browned] – 350F for 15/18 minutes.
- Shrimp [fresh 26-30 ct.] 350F for 10 minutes.
- Salmon fillet [6 oz. fresh] 325F for 12/15 minutes.
- Potatoes [90 ct. baked] 375F for 45/60 minutes.
- Pizza [frozen 14"] 400F for 18 minutes.
- "Pocket" type sandwiches 350F for 18/20 minutes.
- Mozzarella sticks 350F for 10 minutes.



UNOX S.p.A.

CADCO Ltd.

MINI ROBERTA MANUAL

XA006

model: **OV-250**

07-2003

ENGLISH

TECHNICAL DATA

POWER - AMPERAGE	kW 1,440 - 12A
FREQUENCY	60 Hz
POWER SUPPLY CABLE TYPE	SJTOW
POWER SUPPLY CABLE EXTERNAL Ø	10 ÷ 16 mm
VOLTAGE / CABLE SECTION	120 V~ / AWG 14 x 3

ESPAÑOL

DATOS TECNICOS

POTENCIA - AMPERES	kW 1,440 - 12A
FRECUENCIA	60 Hz
TIPO CABLE DE ALIMENTACION	SJTOW
Ø EXTERNO CABLE DE ALIMENTACION	10 ÷ 16 mm
TENSION / SECCION CABLE DE ALIMENT.	120 V~ / AWG 14 x 3

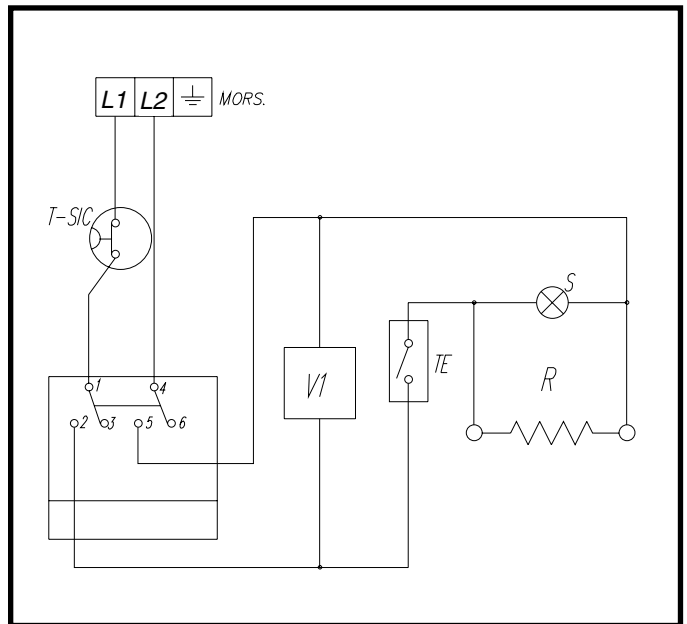
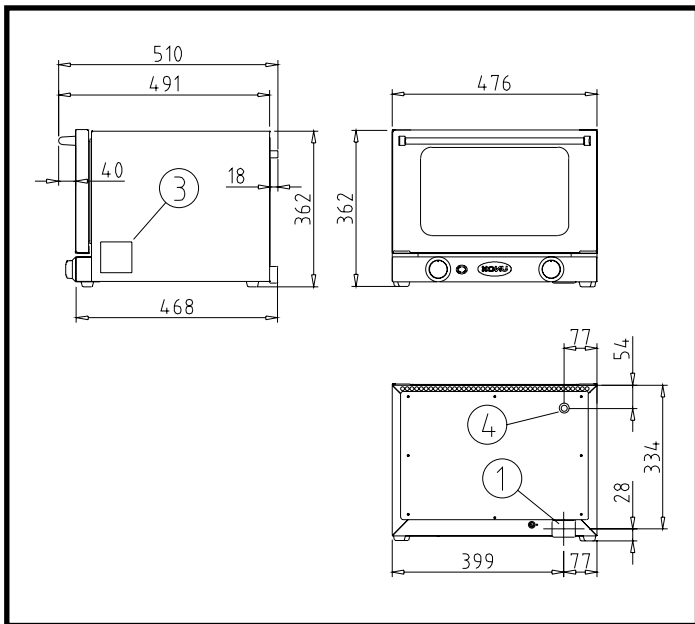

ENGLISH - LEGEND

DRAWINGS - ELECTRICAL SCHEMAS

- 1. TERMINAL BOARD
- 2. EQUIPOTENTIAL TERMINAL SITE
- 3. TECHNICAL DATA PLATE
- 4. HOT SMOKE DISCHARGE
- LM OVEN INTERNAL LAMP
- MO TERMINAL BOARD
- R HEATING ELEMENT
- S PILOT LIGHT
- SIC OVERRIDE THERMOSTAT
- T TIMER
- TE THERMOSTAT
- VI MOTOR FAN
- NETWORK GROUND LINE

ESPAÑOL - LEYENDA

DISEÑOS - ESQUEMAS ELECTRICOS

- 1. CAJA CONEXIONES-REGLETA
- 2. SEDE BORNE EQUIPOTENCIAL
- 3. TARJETA CARACT. TECNICAS
- 4. DESCARGA HUMOS CALIENTES
- LM LAMPARA HORNO
- MO CAJA CONEXIONES-REGLETA
- R RESISTENCIA
- S PILOTO ESPIA
- SIC THERMOSTATO DE SEGURIDAD
- T TIMER
- TE THERMOSTATO
- VI MOTO-VENTILADOR
- LINEA DE TIERRA DE LA RED EL.



UL Std N° 197 Commercial Electric
Cooking appliances.
UL Std. No. 1004 Electric Motors.

UNOX S.p.A.

CADCO Ltd.

MINI ARIANNA MANUAL

XA015

model: **OV-350**

07-2003

ENGLISH

TECHNICAL DATA

POWER - AMPERAGE	kW 1,440 - 12A
FREQUENCY	60 Hz
POWER SUPPLY CABLE TYPE	SJTOW
POWER SUPPLY CABLE EXTERNAL Ø	10 ÷ 16 mm
VOLTAGE / CABLE SECTION	120 V~ / AWG 14 x 3

ESPAÑOL

DATOS TECNICOS

POTENCIA - AMPERES	kW 1,440 - 12A
FRECUENCIA	60 Hz
TIPO CABLE DE ALIMENTACION	SJTOW
Ø EXTERNO CABLE DE ALIMENTACION	10 ÷ 16 mm
TENSION / SECCION CABLE DE ALIMENT.	120 V~ / AWG 14 x 3

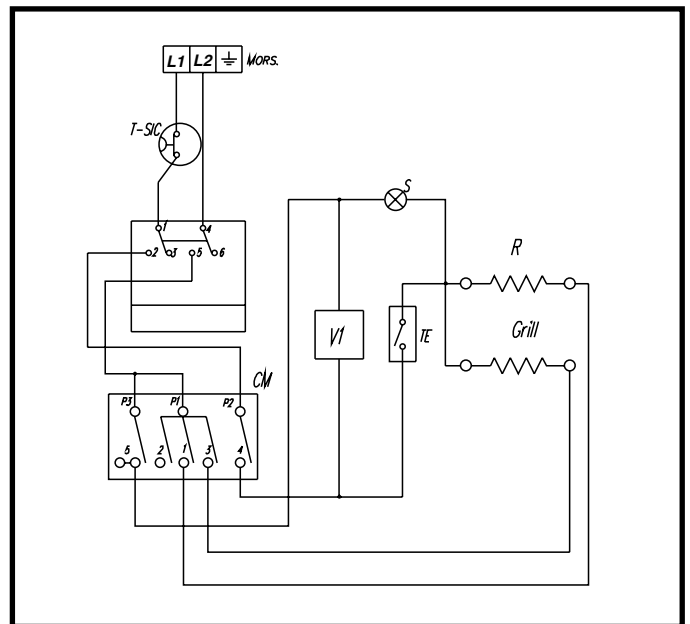
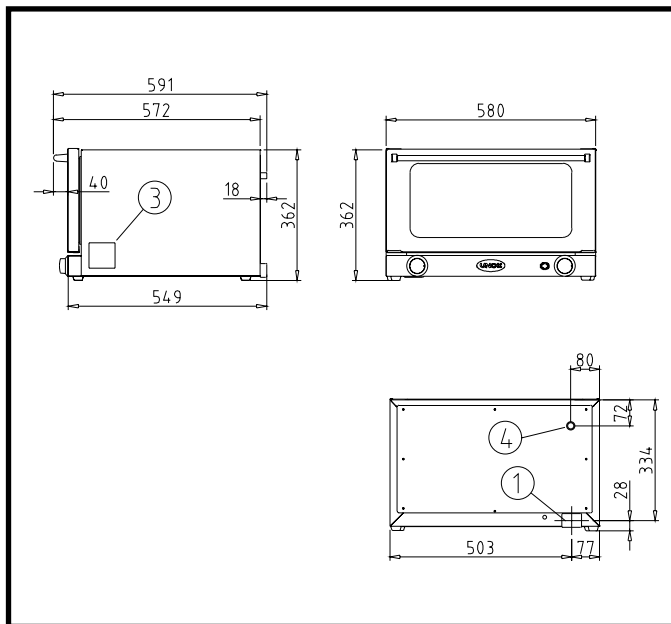

ENGLISH - LEGEND

DRAWINGS - ELECTRICAL SCHEMAS

1.	TERMINAL BOARD
2.	EQUIPOTENTIAL TERMINAL SITE
3.	TECHNICAL DATA PLATE
4.	HOT SMOKE DISCHARGE
LM	OVEN INTERNAL LAMP
MO	TERMINAL BOARD
R	HEATING ELEMENT
S	PILOT LIGHT
SIC	OVERRIDE THERMOSTAT
T	TIMER
TE	THERMOSTAT
VI	MOTOR FAN
⏏	NETWORK GROUND LINE

ESPAÑOL - LEYENDA

DISEÑOS - ESQUEMAS ELECTRICOS

1.	CAJA CONEXIONES-REGLETA
2.	SEDE BORNE EQUIPOTENCIAL
3.	TARJETA CARACT. TECNICAS
4.	DESCARGA HUMOS CALIENTES
LM	LAMPARA HORNO
MO	CAJA CONEXIONES-REGLETA
R	RESISTENCIA
S	PILOTO ESPIA
SIC	TERMOSTATO DE SEGURIDAD
T	TIMER
TE	TERMOSTATO
VI	MOTO-VENTILADOR
⏏	LINEA DE TIERRA DE LA RED EL.



202281

UL Std N° 197 Commercial Electric
Cooking appliances.
UL Std. No. 1004 Electric Motors.



UNOX S.p.A.

CADCO Ltd.

ARIANNA MANUAL

XA030

model: **OV-400**

07-2003

ENGLISH

TECHNICAL DATA

POWER - AMPERAGE	kW 2,650 - 12A
FREQUENCY	60 Hz - 1 Phase
POWER SUPPLY CABLE TYPE	SJTOW
POWER SUPPLY CABLE EXTERNAL Ø	10 ÷ 16 mm
VOLTAGE / CABLE SECTION	208-240 V~ / AWG 14

ESPAÑOL

DATOS TECNICOS

POTENCIA - AMPERES	kW 2,650 - 12A
FRECUENCIA	60 Hz - 1 Fase
TIPO CABLE DE ALIMENTACION	SJTOW
Ø EXTERNO CABLE DE ALIMENTACION	10 ÷ 16 mm
TENSION / SECCION CABLE DE ALIMENT.	208-240 V~ / AWG 14

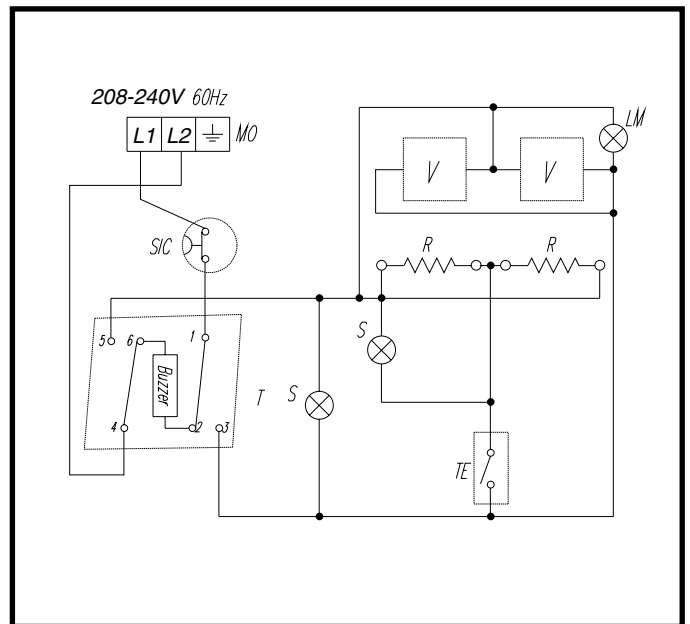
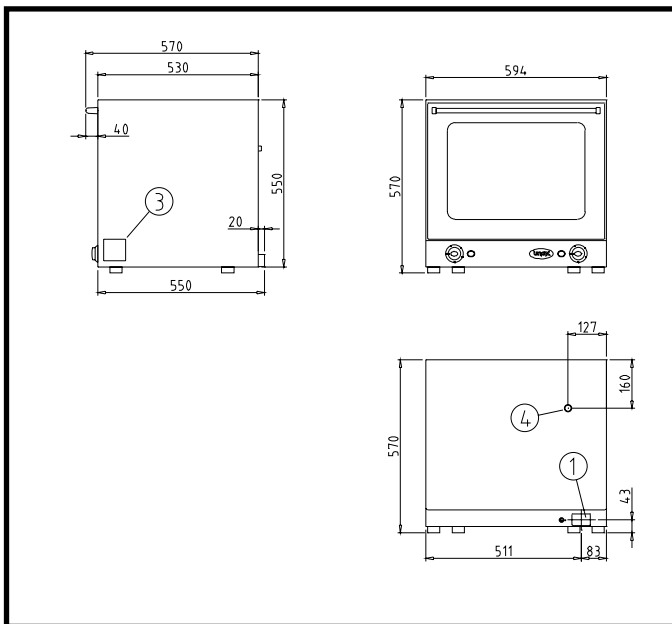

ENGLISH - LEGEND

DRAWINGS - ELECTRICAL SCHEMAS

- 1. TERMINAL BOARD
- 2. EQUIPOTENTIAL TERMINAL SITE
- 3. TECHNICAL DATA PLATE
- 4. HOT SMOKE DISCHARGE
- LM OVEN INTERNAL LAMP
- MO TERMINAL BOARD
- R HEATING ELEMENT
- S PILOT LIGHT
- SIC OVERRIDE THERMOSTAT
- T TIMER
- TE THERMOSTAT
- V1 MOTOR FAN
- NETWORK GROUND LINE

ESPAÑOL - LEYENDA

DISEÑOS - ESQUEMAS ELECTRICOS

- 1. CAJA CONEXIONES-REGLETA
- 2. SEDE BORNE EQUIPOTENCIAL
- 3. TARJETA CARACT. TECNICAS
- 4. DESCARGA HUMOS CALIENTES
- LM LAMPARA HORNO
- MO CAJA CONEXIONES-REGLETA
- R RESISTENCIA
- S PILOTO ESPIA
- SIC THERMOSTATO DE SEGURIDAD
- T TIMER
- TE THERMOSTATO
- V1 MOTO-VENTILADOR
- LINEA DE TIERRA DE LA RED EL.



202281

UL Std N° 197 Commercial Electric
Cooking appliances.
UL Std. No. 1004 Electric Motors.



UNOX S.p.A.

CADCO Ltd.

ELENA MANUAL

XA085

model: **OV-500**

07-2003

ENGLISH

TECHNICAL DATA

ELECTRICAL POWER	kW 3,26
FREQUENCY	60 Hz 1 Phase
POWER SUPPLY CABLE TYPE	SJTOW
POWER SUPPLY CABLE EXTERNAL Ø	10 ÷ 16 mm
VOLTAGE / CABLE SECTION	208-240 V~ / AWG 12
WATER PRESSURE	kPa 50 - 200

ESPAÑOL

DATOS TECNICOS

POTENCIA	kW 3,26
FRECUENCIA	60 Hz 1 Face
TIPO CABLE DE ALIMENTACION	SJTOW
Ø EXTERNO CABLE DE ALIMENTACION	10 ÷ 16 mm
TENSION / SECCION CABLE DE ALIMENT.	208-240 V~ / AWG 12
PRESION AGUA	kPa 50 - 200

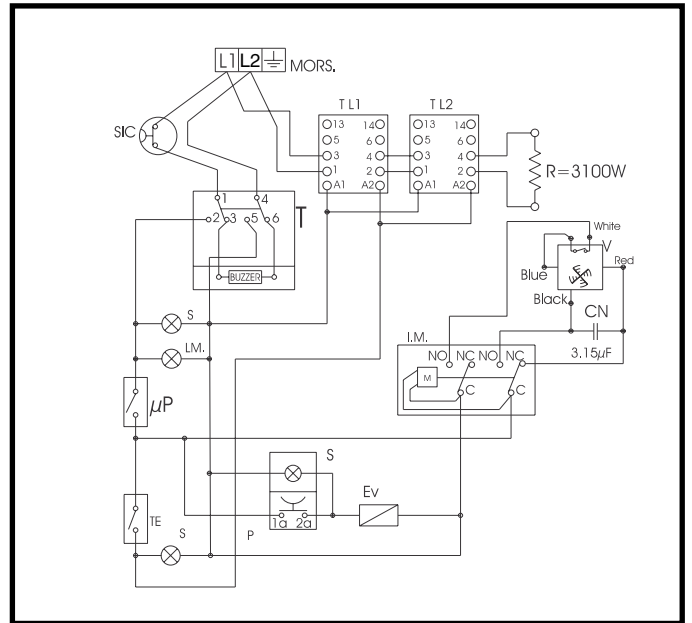
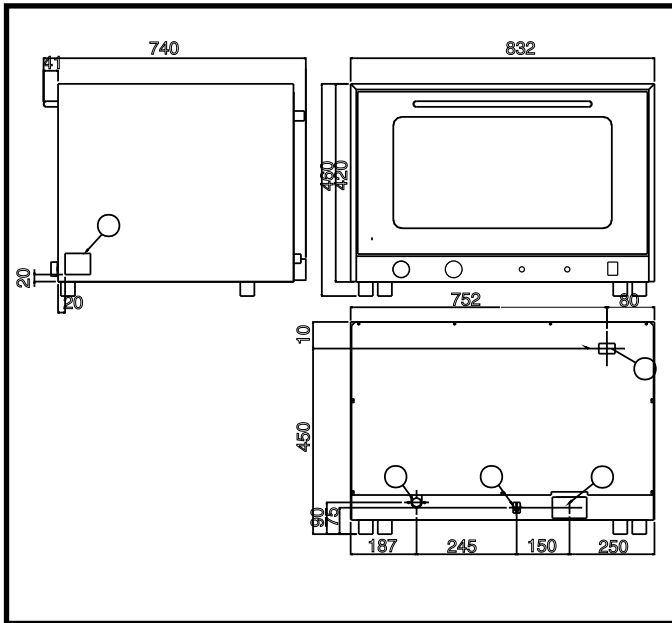

ENGLISH - LEGEND

DRAWINGS - ELECTRICAL SCHEMAS

- | | |
|-----|-----------------------------|
| 1. | TERMINAL BOARD |
| 2. | EQUIPOTENTIAL TERMINAL SITE |
| 3. | TECNICAL DATA PLATE |
| 4. | HOT SMOKE DISCHARGE |
| LM | OVEN INTERNAL LAMP |
| MO | TERMINAL BOARD |
| R | HEATING ELEMENT |
| S | PILOT LIGHT |
| SIC | OVERRIDE THERMOSTAT |
| T | TIMER |
| TE | THERMOSTAT |
| VI | MOTOR FAN |
| | NETWORK GROUND LINE |

ESPAÑOL - LEYENDA

DISEÑOS - ESQUEMAS ELECTRICOS

- | | |
|-----|-------------------------------|
| 1. | CAJA CONEXIONES-REGLETA |
| 2. | SEDE BORNE EQUIPOTENCIAL |
| 3. | TARJETA CARACT. TECNICAS |
| 4. | DESCARGA HUMOS CALIENTES |
| LM | LAMPARA HORNO |
| MO | CAJA CONEXIONES-REGLETA |
| R | RESISTENCIA |
| S | PILOTO ESPIA |
| SIC | TERMOSTATO DE SEGURIDAD |
| T | TIMER |
| TE | TERMOSTATO |
| VI | MOTO-VENTILADOR |
| | LINEA DE TIERRA DE LA RED EL. |



202281

UL Std N° 197 Commercial Electric
Cooking appliances.
UL Std. No. 1004 Electric Motors.



UNOX S.p.A.

CADCO Ltd.

ROSSELLA MANUAL

XA090

model: **OV-600**

07-2003

ENGLISH

TECHNICAL DATA

ELECTRICAL POWER	kW 5,4
FREQUENCY	60 Hz 1 Phase
POWER SUPPLY CABLE TYPE	SJTOW
POWER SUPPLY CABLE EXTERNAL Ø	10 ÷ 16 mm
VOLTAGE / CABLE SECTION	208-240 V~ / AWG 10
WATER PRESSURE	kPa 50 - 200

ESPAÑOL

DATOS TECNICOS

POTENCIA	kW 5,4
FRECUENCIA	60 Hz 1 Face
TIPO CABLE DE ALIMENTACION	SJTOW
Ø EXTERNO CABLE DE ALIMENTACION	10 ÷ 16 mm
TENSION / SECCION CABLE DE ALIMENT.	208-240 V~ / AWG 10
PRESION AGUA	kPa 50 - 200

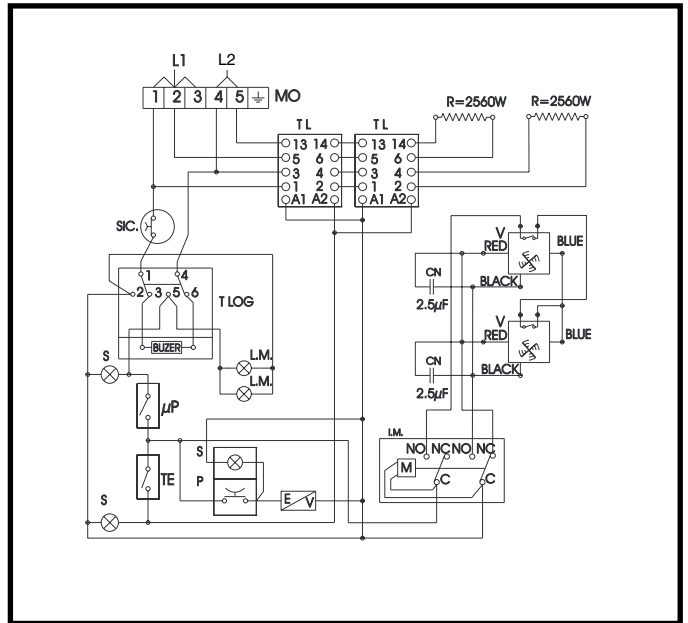
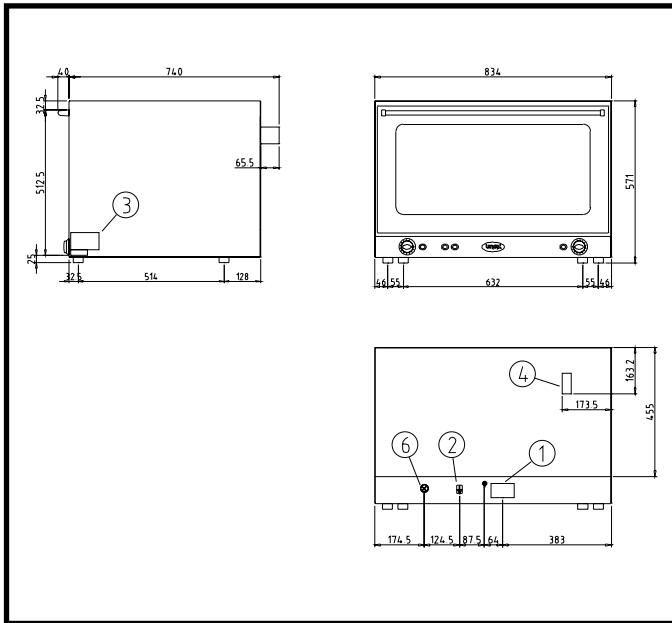

ENGLISH - LEGEND

DRAWINGS - ELECTRICAL SCHEMAS

- 1. TERMINAL BOARD
- 2. EQUIPOTENTIAL TERMINAL SITE
- 3. TECHNICAL DATA PLATE
- 4. HOT SMOKE DISCHARGE
- LM OVEN INTERNAL LAMP
- MO TERMINAL BOARD
- R HEATING ELEMENT
- S PILOT LIGHT
- SIC OVERRIDE THERMOSTAT
- T TIMER
- TE THERMOSTAT
- VI MOTOR FAN
- NETWORK GROUND LINE

ESPAÑOL - LEYENDA

DISEÑOS - ESQUEMAS ELECTRICOS

- 1. CAJA CONEXIONES-REGLETA
- 2. SEDE BORNE EQUIPOTENCIAL
- 3. TARJETA CARACT. TECNICAS
- 4. DESCARGA HUMOS CALIENTES
- LM LAMPARA HORNO
- MO CAJA CONEXIONES-REGLETA
- R RESISTENCIA
- S PILOTO ESPIA
- SIC TERMOSTATO DE SEGURIDAD
- T TIMER
- TE TERMOSTATO
- VI MOTO-VENTILADOR
- LINEA DE TIERRA DE LA RED EL.



202281

UL Std N° 197 Commercial Electric
Cooking appliances.
UL Std. No. 1004 Electric Motors.